

• SPECIFICATION •

• 4593/HS - INDUSTRIAL BRIDGE MIXER WITH HANDLE SMOOTH

- HANDCRAFTED IN THE UK
- 1/4 TURN CERAMIC DISC FLOW CONTROL
- SINGLE FLOW SPOUT
- FITTED WITH 15MM CHECK VALVES
- IDEALLY INSTALLED IN EQUAL PRESSURE SYSTEMS

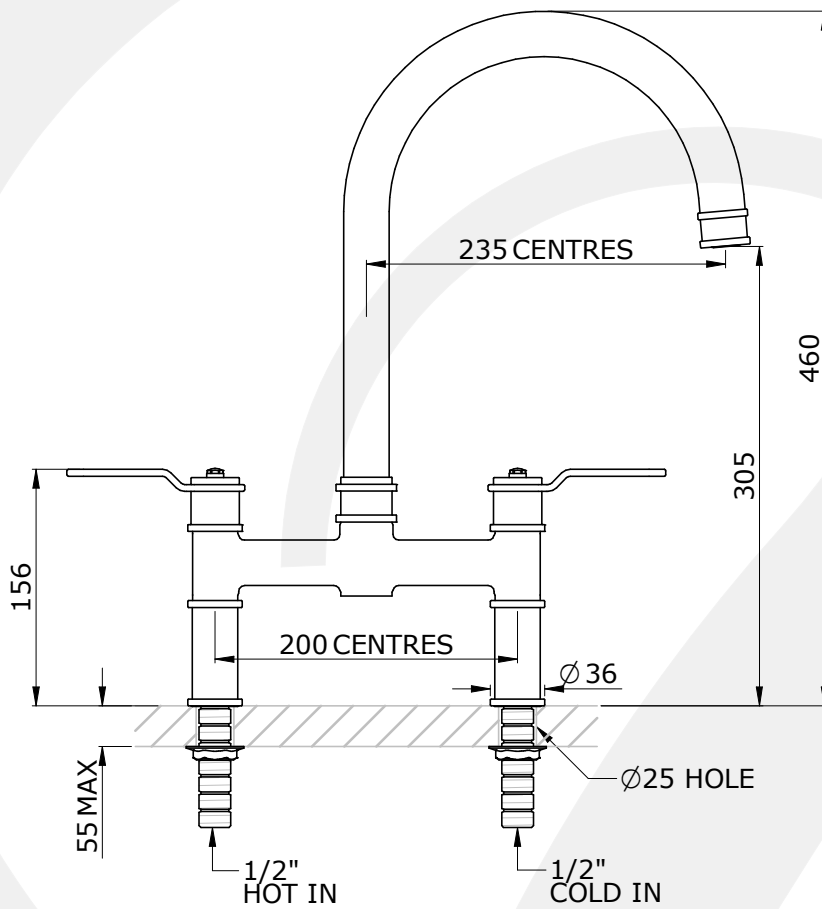

AVAILABLE FINISHES:

- CHROME
- NICKEL
- PEWTER
- POLISHED BRASS
- SATIN BRASS
- AGED BRASS
- GOLD
- ENGLISH BRONZE

• TEMP RANGE:
MIN 1°C / 34°F
MAX 70°C / 158°F

• RECOMMENDED
SUPPLY PRESSURE:
MIN 0.5BAR / 7PSI
MAX 5BAR / 75PSI

• PACKED WEIGHT:
3.1 KG

AVAILABLE OPTIONS:

- TEXTURED LEVER VARIANT
- PULL-DOWN VERSIONS
- 5.7L/MIN REGULATED SPOUT (PREFIX AR.)

FLOW RATES:

- 1 BAR: 18.6 L/MIN
- 2 BAR: 21.2 L/MIN
- 3 BAR: 21.2 L/MIN